

PRODUCT TECHNICAL SHEET

TECHNICAL DRAWING

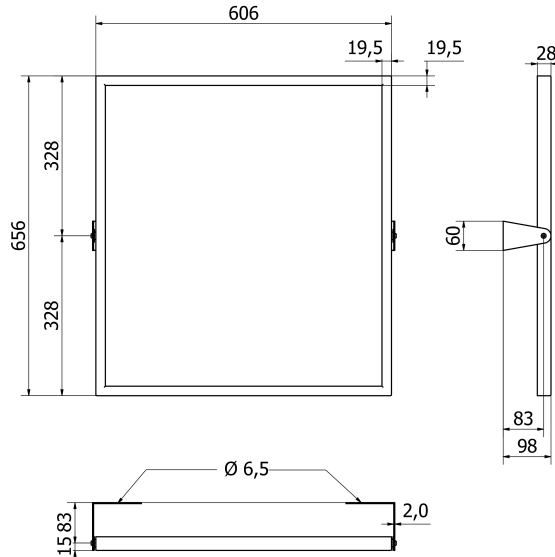

PHOTO



PRODUCT FAMILY: MIRRORS

CODE: 350N-B

DESCRIPTION: Adjustable tilting mirror.

MECHANICAL PERFORMANCE:

Safety backed glass

CERTIFICATIONS:

TUV system certification UNI EN ISO 9001:2008.

PRODUCT FEATURES:

Adjustable tilting mirror, complete with wall mounting bracket. Dimensions: 607 x 657 mm.

Safety backed glass attached to the frame by means of silicone. The backed glass complies with the technical rule EN 12600 class 2B2.

In case of impact on the glass, it meets the requirements of the following regulations: BS 6206 1981 Class B; ANSIz 97.1 1984. It ensures double safety:

- the back facade features a plastic film which holds the glass shards in place;
- the mirror does not breakthrough.

FIXING (INSTALLATION):

Wall mounting by n° 2 plugs.

Plugs are not included in the package.

Choose suitable plugs according to the type of wall.

Check the correct tightening of the handles.

PRODUCT COMPOSITION:

N° 1 Frame - Metal sheet FeP04 25/10 - Zinc-coated, Painted RAL9016

N° 1 Bracket - Metal sheet FeP04 25/10 - Zinc-coated, Painted RAL9016

N° 2 Handles - Plastic - Galvanized steel

N° 1 Mirror glass - Glass - Silver - Safety thick. 5 mm Mirox

MAINTENANCE:

Check the correct fastening of the accessories periodically.

Perform a proper cleaning with water and soap, do not use abrasive or corrosive agents or coarse sponges.

PRODUCT PACKAGING:

Packed in PE bag, n° 2 polystyrene sheets and cardboard box 620 x 710 x 80 mm.

Weight: 9,3 kg

The above mentioned information cannot be considered as binding.

reserves the right to make technical and aesthetic changes without any prior notice.

ST_PRODOTTO: 350N-E	APPROVATO - 1 R.T.
REV.01 DEL 19/12/19	

ISO 9001 Quality Management System certified by TÜV Italia Srl since 2005

Via M. Curie, 7 - 46034 Borgo Virgilio (Mantova) ITALY

Tel. + 39 0376 4473

www.thermomat.com - info@thermomat.com